

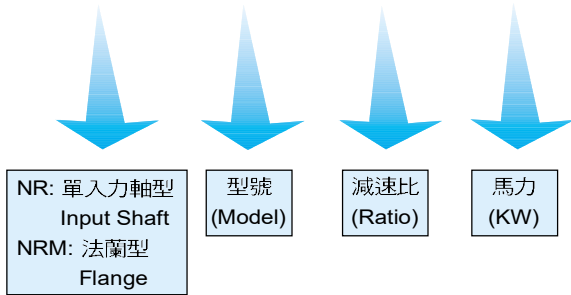

鋁合金中空型渦輪減速機

機種代號說明：

NRM - 030 - 010 - 0.4



使用差異 *Difference in usage*

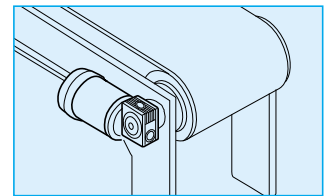
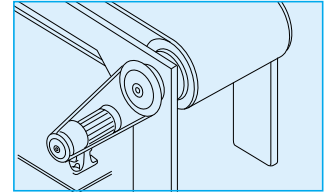
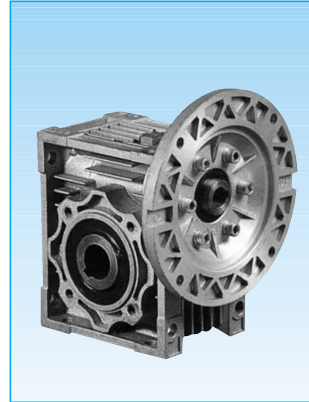

43

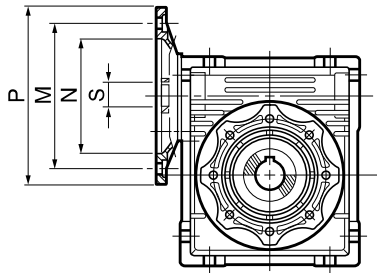

不佔空間及降低成本的代名詞

- 自鎖功能:**
對於一般需要微保持力的使用場合，可節省裝置制動器的費用，如（爬坡型輸送機）。
- 安全性高:**
使用不同於傳統的傳動方式，免鏈輪、皮帶輪，傳動結構不外露，減少作業人員的傷害。
- 可多面安裝，無角度限制:**
全系列產品，每個平面，皆有固定孔，您可選擇安裝時所需的方向、角度安裝。

標準馬達直結型選擇表（一段型）

框號	PAM IEC	馬力 (4P) kW	N	M	P	S (Input Shaft Dia. 入力軸徑/Gear Ratio 減速比)											
						5	7.5	10	15	20	25	30	40	50	60	80	100
NRM030 鋁合金	63B14	0.2	60	75	90	11	11	11	11	11	11	11	11	11	-	-	-
	TL, 方型	0.06/0.09	83	104	90	12	12	12	12	12	12	12	12	12	12	-	-
NRM040 鋁合金	71B5	0.4	110	130	160	14	14	14	14	14	14	14	-	-	-	-	-
	71B5	0.2	110	130	160	11	11	11	11	11	11	11	11	11	11	-	-
	TL, 方型	0.09	83	104	90	11	11	11	11	11	11	11	11	11	11	-	-
NRM050 鋁合金	80B5	0.75	130	165	200	19	19	19	19	19	19	19	-	-	-	-	-
	71B5	0.4	110	130	160	14	14	14	14	14	14	14	14	14	14	-	-
	71B5	0.2	110	130	160	11	11	11	11	11	11	11	11	11	11	11	11
NRM063 鋁合金	90B5	1.5	130	165	200	24	24	24	24	24	24	24	-	-	-	-	-
	80B5	0.75	130	165	200	19	19	19	19	19	19	19	19	19	-	-	-
	71B5	0.4	110	130	160	-	-	14	14	14	14	14	14	14	14	14	14
NRM075 鋁合金	100/112B5	2.2/3.7	180	215	250	-	28	28	28	-	-	-	-	-	-	-	-
	90B5	1.5	130	165	200	-	24	24	24	24	24	24	24	-	-	-	-
	80B5	0.75	130	165	200	-	-	-	-	19	19	19	19	19	19	19	19
NRM090 鑄鐵	100/112B5	2.2/3.7	180	215	250	-	28	28	28	28	28	28	-	-	-	-	-
	90B5	1.5	130	165	200	-	24	24	24	24	24	24	24	24	24	-	-
	80B5	0.75	130	165	200	-	-	-	-	-	-	-	19	19	19	19	19
NRM110 鑄鐵	132B5	5.5/7.5	230	265	300	-	38	38	38	38	-	-	-	-	-	-	-
	100/112B5	2.2/3.7	180	215	250	-	28	28	28	28	28	28	28	28	28	-	-
	90B5	1.5	130	165	200	-	-	-	-	-	24	24	24	24	24	24	24
NRM130 鑄鐵	80B5	0.75	130	165	200	-	-	-	-	-	-	-	-	-	-	19	19
	132B5	5.5/7.5	230	265	300	-	38	38	38	38	38	38	38	-	-	-	-
	100/112B5	2.2/3.7	180	215	250	-	-	-	-	-	28	28	28	28	28	28	28
	90B5	1.5	130	165	200	-	-	-	-	-	-	-	-	-	-	24	24

*另有扭力臂、單出力軸、雙出力軸、輸出法蘭可選配。(Torque arm, single shaft, dual shaft, output flange are optional.)

以上數值若有變動，恕不另行通知 We reserve the right to change without further notice.

Hollow Shaft Worm Gear Reducer

NR/NRM 尺寸圖 (一段型) *Dimensions (One stage type)*

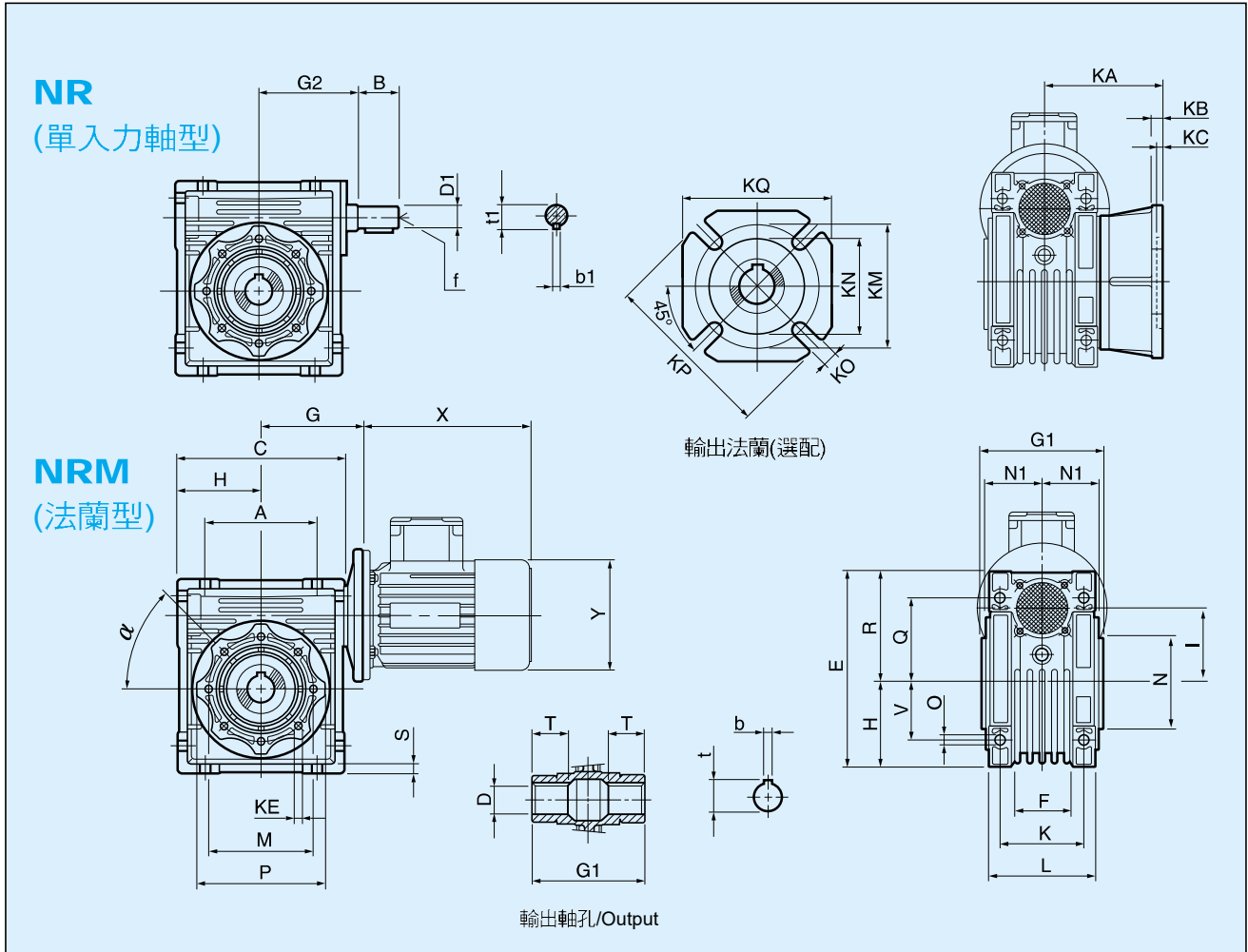

尺寸 型式	A	B	C	D (H7)	D1 (j6)	E	F	G	G1	G2	H	I	L	M	N	N1	O	P	Q	R	S	T
030	54	20	80	14	9	98.5	32	57	65	51	40	30	56.5	65	55	30	6	75	44	57	6.5	21
040	70	23	101	18 (19)	11	122	43	72	80.5	60	50	40	71	75	60	38	7	90	55	72	6.5	26
050	80	30	120.5	25 (24)	14	145	49	80	93.5	74	60	50	85	85	70	44.35	8	100	64	85	7.5	30
063	100	40	148	25 (28)	19	174	72	102	112.5	90	72	63	103	95	80	53	8	110	80	102	7.5	36
075	120	50	175	28 (35)	24	205	74	113.5	120	105	86	75	112	115	95	59	11	140	93	119	8	40

尺寸 型式	V	K	KA	KB	KC	KE	KM	KN(HB)	KO	KP	KQ	b	b1	f	t	t1	Kg
030	27	44	55	6	3.7	M6x11 n. 4	68	50	6 n. 4	80	70	5	3	—	16.3	10.2	1.2
040	35	60	68	7.5	5.7	M6x10 n. 4	74	60	9 n. 4	110	95	6 (6)	4	—	20.8 (21.8)	12.5	2.3
050	40	70	91.5	9	5.7	M8x10 n. 4	85	70	11 n. 4	124	110	8 (8)	5	M6	28.3 (27.3)	16.0	3.5
063	50	85	82.5 (113)	10 (11)	6 (7)	M8x14 n. 8	150	115	11 n. 4	180	145	8 (8)	6	M6	28.3 (31.3)	21.5	6.2
075	60	90	111.5	13	6	M8x14 n. 8	162	130	14 n. 4	198	168	8 (10)	8	M8	31.3 (38.3)	27.0	9

圖中X與Y軸的尺寸請參考所使用的馬達。

Please refer to the motor used for the size of X and Y in the figure.

以上數值若有變動，恕不另行通知 We reserve the right to change without further notice.