

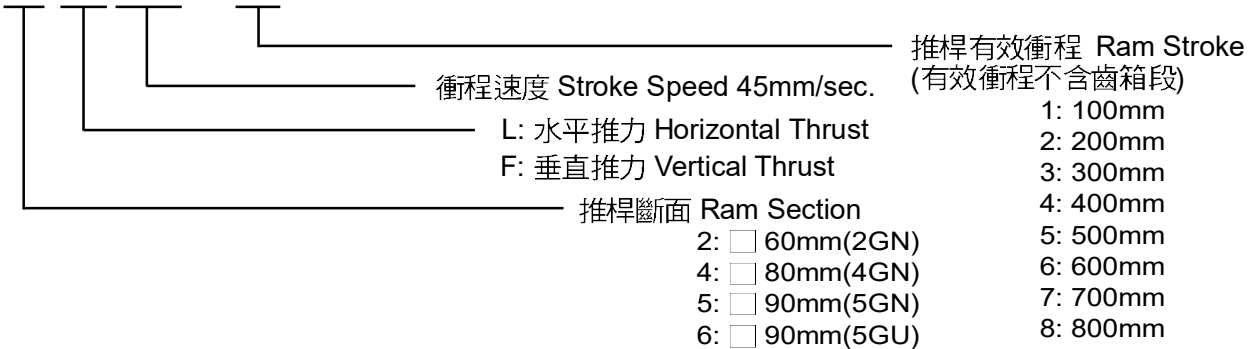

25

## GNT · GUT 直線型減變速馬達 Linear Type Gear Head with Motor

4 L 45 - 3



### 直線型齒輪箱特性表 Specifications of GNT (GUT) Type Gear Head with Motor

型號 Model No.	排桿重量 Weight (kg)	配合馬達機種 Applicable Motor	最大推力 Max. Thrust (kg)	基本速度 Speed (mm/sec)	直吊荷重 Permissible O.H.L. (kg)	衝程 Stroke (mm)	排桿重量 Weight (kg)	衝程 Stroke (mm)	排桿重量 Weight (kg)
2 <sub>F</sub> <sup>L</sup> -□-□	0.35		20	10	3	100	0.19	400	0.53
				20		200		500	
				30		300		600	
				40		400		600	
				50		300		600	
4 <sub>F</sub> <sup>L</sup> -□-□	0.65		70	10	5	100	0.37	500	1.34
				20		200		600	
				30		300		700	
				40		400		800	
				50		400		800	
5 <sub>F</sub> <sup>L</sup> -□-□	0.87		100	10	8	100	0.73	500	2.15
				20		200		600	
				30		300		700	
				40		400		800	
				50		400		800	
6 <sub>F</sub> <sup>L</sup> -□-□	2		140	10	8	100	0.73	500	2.15
				20		200		600	
				30		300		700	
				40		400		800	
				50		400		800	

※ 最大推力以10mm/sec.及水平出力為基準；速度加快，推力降低。

### 用途例 Application

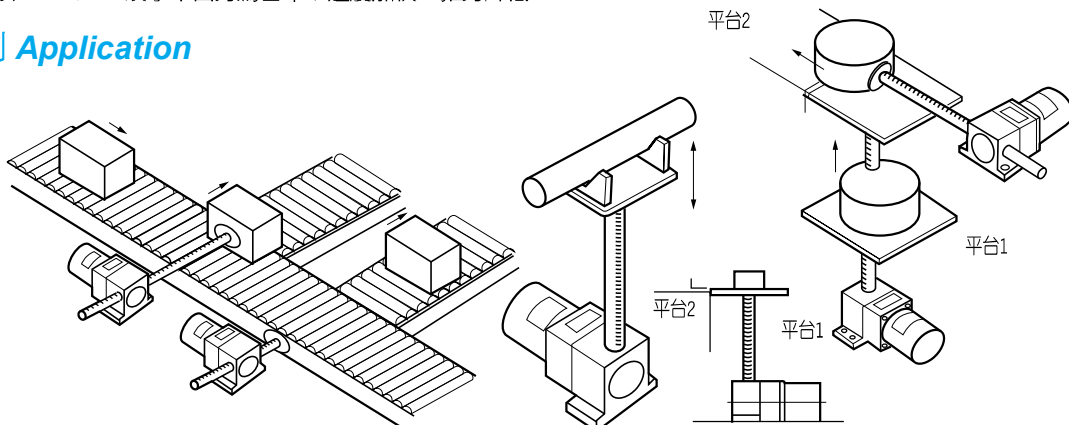

\*以上數值若有變動，恕不另行通知\* We reserve the right to change without further notice.

**6W # 2**

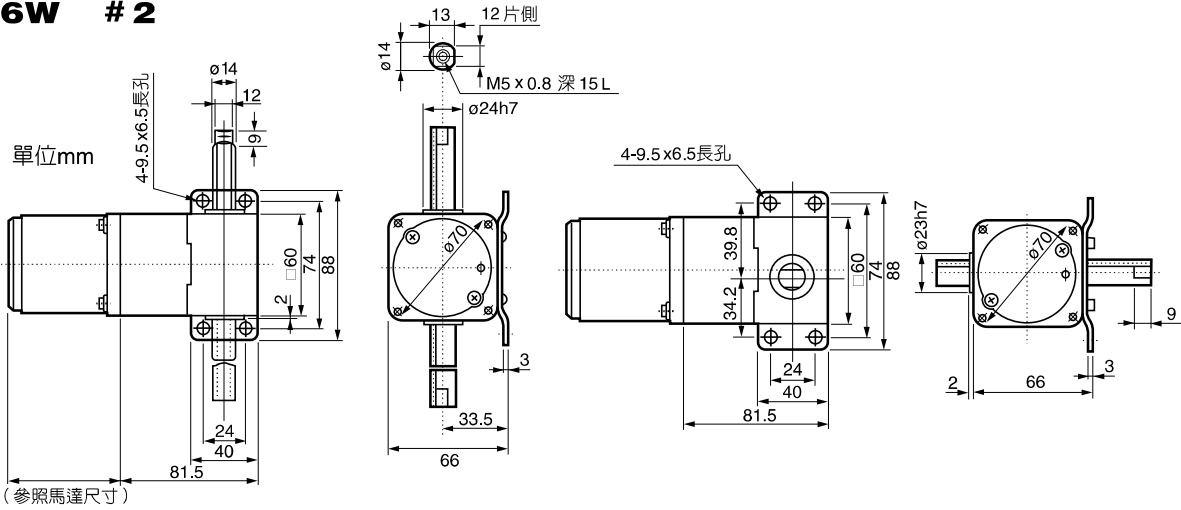

**25W # 4**

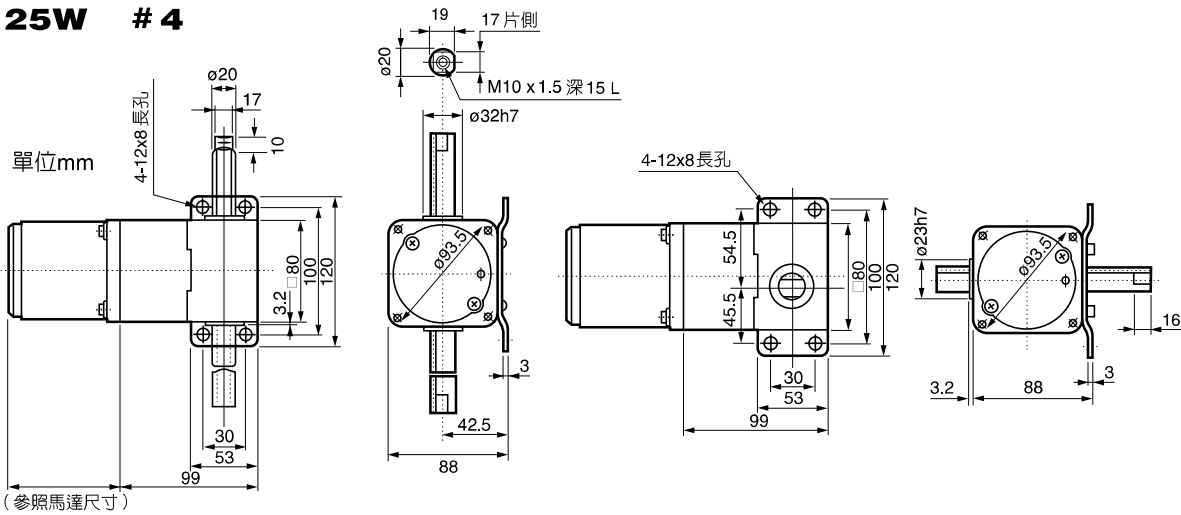

**40W # 5 (GN)  
60W # 6 (GU)  
90W  
120W  
150W**

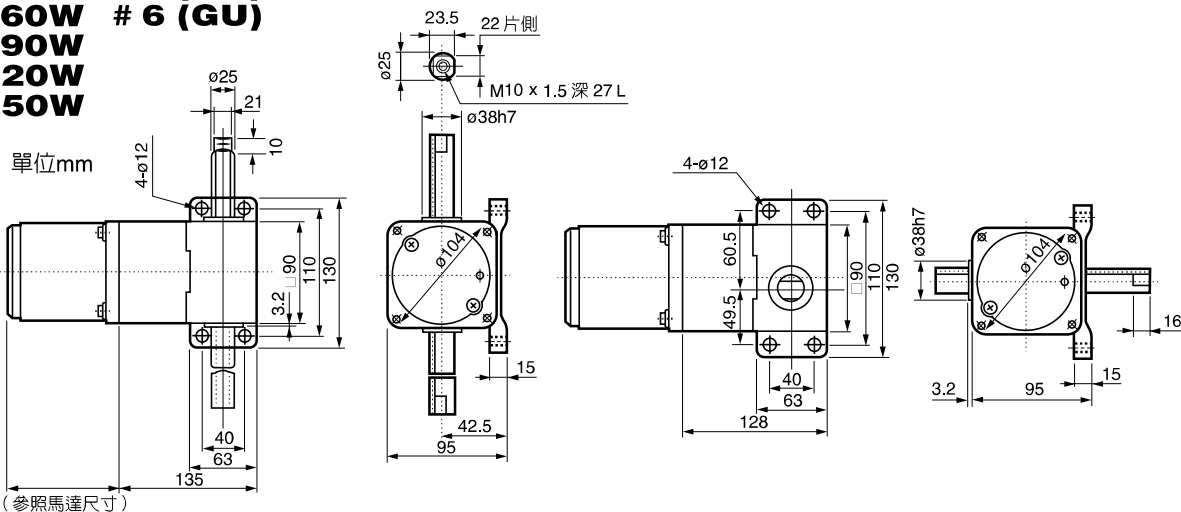

\*以上數值若有變動，恕不另行通知\* We reserve the right to change without further notice.