

ALUMINUM ALLOY WORM REDUCER SERIES

鋁合金蝸輪減速機系列

MODEL : NEOF

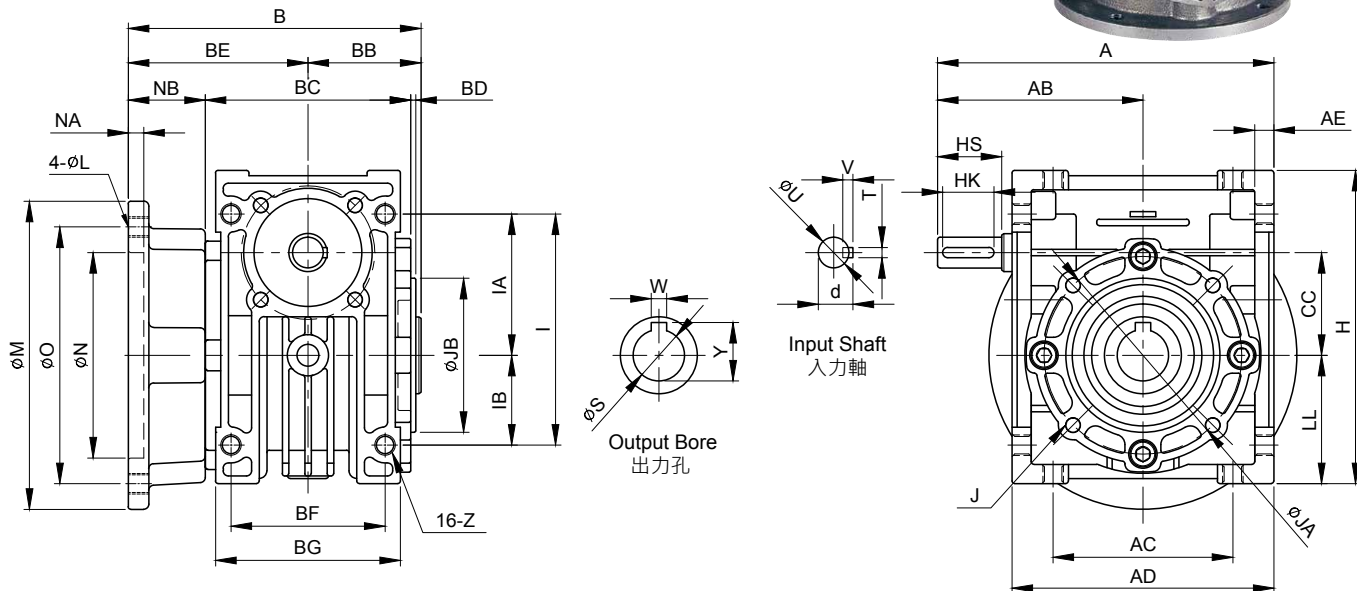

unit: mm

型號 Model	減速比 Ratio	馬力 HP	A	AB	AC	AD	AE	B	BE	NB	BB	BC	BD	BF	BG	CC	LL	H	I	IA	IB	Z
30	5~60	40W·60W	105	65	55	80	6	92.5	60	30	32.5	60	2	45	58	30	40	98	72	45	27	M6
	5~40	90W																				
	5~30	1/4																				
40	5~60	1/4	131	80	70	102	7.5	114	70	30	44	80	2	60	72	40	50	122	90	55	35	M8
	5~30	1/2																				
	5~60	1/4																				
50	5~50	1/2	155	95	80	120	8.5	129	80	33	49	94	3	70	85	50	60	145	105	65	40	M10
	5~30	1																				
	5~60	1/2																				
60	5~50	1	193	120	100	146	10	154	100	49	54	102	3	85	102	60	75	180	136	83	53	M10
	5~15	2																				
	5~60	1/2																				
70	5~60	1	225	140	120	170	12	164	100	41	64	118	3	90	110	70	85	200	150	90	60	M10
	5~40	2																				

型號 Model	減速比 Ratio	馬力 HP	入力軸 Input Shaft				出力法蘭及出力孔 Output Flange & Output Shaft											重量 Weight (kg)
			HS	U	d	TxVxHK	N	NA	O	M	L	W	S	Y	JA	JB	Jx 牙深 Deep	
30	5~60	40W·60W	20	11	12.5	4x4x16	70	5	85	100	M6	5	14	16.3	65	55	4-M6-9	1.33
	5~40	90W																
	5~30	1/4																
40	5~60	1/4	25	12	13.5	4x4x20	80	6	100	120	M8	6	20	22.8	77	60	4-M6-9	2.45
	5~30	1/2																
	5~60	1/4																
50	5~50	1/2	30	15	17	5x5x25	95	6	120	140	M10	8	25	28.3	95	70	4-M6-9	4.02
	5~30	1																
	5~60	1/2																
60	5~50	1	40	18	20.5	6x6x35	130	7	160	180	M10	8	25	28.3	120	80	4-M8-12	6.54
	5~15	2																
	5~60	1/2																
70	5~60	1	45	22	25	7x7x40	150	7	185	210	M12	8	30	33.3	140	90	4-M10-15	9.5
	5~40	2																

選配馬力時，請參考「減速機參數」(第15頁)。Please refer to page I5 "Reducers Parameter".