

MODEL : FA

單段 1-Stage

RATIO : 3, 4, 5, 7, 10

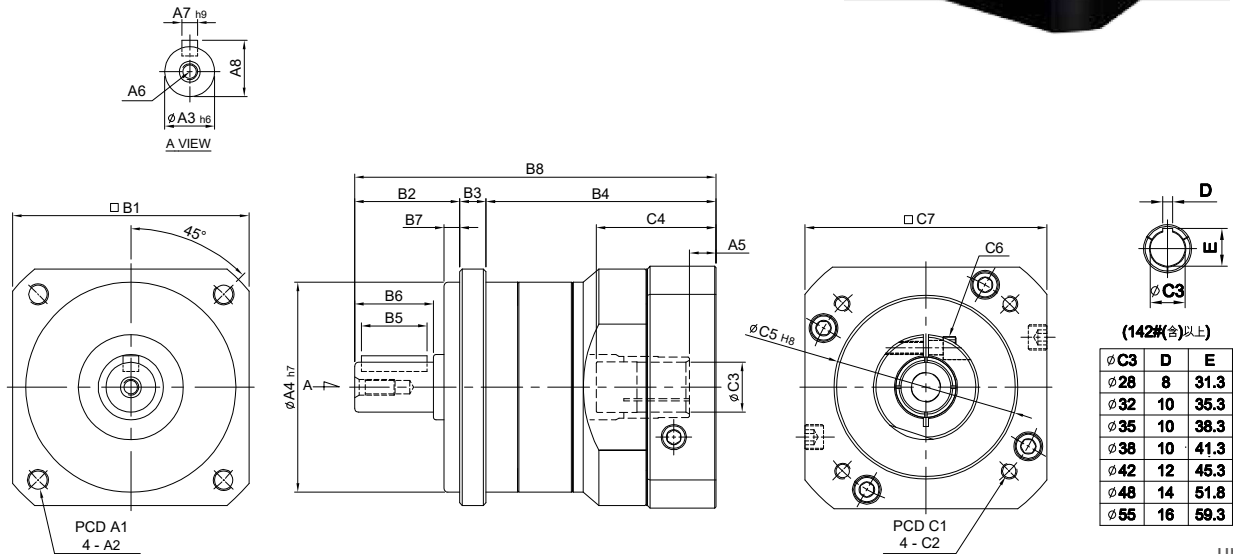
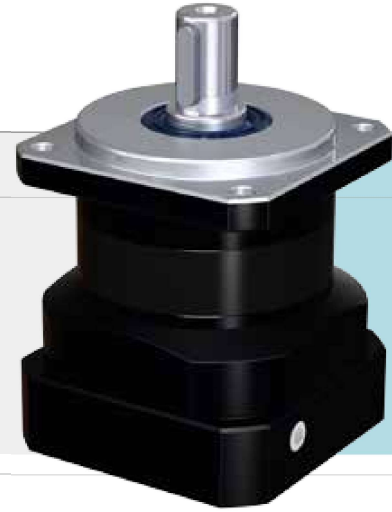

unit: mm

Model Code	50	70	80	90	100	120	142	180
A A1	60	76	90	100	115	135	165	215
A2	M5 x P0.8	Φ5.5	M6 x P1.0	M8 x P1.25	M8 x P1.25	M10 x P1.5	M12 x P1.75	M14 x P2.0
A3	12	16	19	19	24	32	40	55
A4	50	60	70	80	90	110	130	160
A5	4.5	6	10	10	8 · 22.5	10	10	11.5
A6	M4 x P0.7 deep 11	M5 x P0.8 deep 14	M6 x P1.0 deep 15	M6 x P1.0 deep 15	M8 x P1.25 deep 20	M10 x P1.5 deep 23	M10 x P1.5 deep 23	M14 x P2.0 deep 32
A7	4	5	6	6	8	10	12	16
A8	13.5	18	21.5	21.5	27	35	43	59
B B1	52	70	80	90	102	120	142	180
B2	32	36	50	40	61	72	87	106
B3	6	7	11	10	13	10	15	
B4	58.5	72/80	76.5	87.5	89.5/104	123/133	158.5	201.5/204.5
B5	15	20	25	25	30	40	65	70
B6	20	28	30	30	40	50	74	82
B7	4.5	7	5	6	5	10	10	2
B8	96.5	115 · 123	137.5	137.5	163.5 · 178	205 · 215	260.5	323.5 · 326.5
C C1	45 · 46 · 48.5 · 63 · 70	70 · 75 · 85	70 · 90 · 100 · 115	90 · 100 · 115 · 145	90 · 100 · 115 · 145	115 · 145 · 165	130 · 145 · 165 · 175 · 215	149 · 200 · 215 · 265 · 300
C2	M3 · M4 · M5	M5 · M6	M5 · M6	M6 · M8	M6 · M8	M6 · M8 · M10	M8 · M10 · M12	M8 · M12 · M16
C3	8 · 10 · 11 · 14	11 · 14 · 16 · 19	16 · 19	16 · 19	19 · 22 · 24	22 · 24 · 28 · 32	28 · 32 · 35 · 38	35 · 38 · 42 · 48 · 55
C4	32	33.5 · 41.5	45.5	45.5	51 · 65.5	67 · 77	84.5	114.5 · 117.5
C5	30 · 40 · 50	50 · 60 · 70	50 · 70 · 80 · 95	70 · 80 · 95 · 110	70 · 80 · 95 · 110	95 · 110 · 130	110 · 130 · 180	114.3 · 180 · 230 · 250
C6	M4 x P0.7	M5 x P0.8	M5 x P0.8	M5 x P0.8	M6 x P1.0	M8 x P1.25	M10 x P1.5	M10 x P1.5
C7	46 · 55 · 60	64 · 70 · 80	80 · 92 · 110	92 · 110 · 130	92 · 110 · 130	122 · 130 · 150	146 · 150 · 190	182 · 200 · 250 · 265



規格 Model No.	代號	單位 Unit	速比 Ratio	50	70	80	90	100	120	142	180
額定輸出扭矩 Rated Output Torque (Nominal output torque)	T_{2N}	Nm	3	19	54	112	112	165	286	550	1,0
			4	16	48	110	110	146	255	490	
			5	16	45	108	108	160	264	510	
			7	15	41	105	105	149	245	470	97
			10	14	40	100	100	141	234	450	930
最大加速扭矩 Max. Acceleration Torque	T_{2B}	Nm	3	34	97	202	202	297	515	990	1,90
			4	29	86	198	198	263	459	880	1,
			5	29	81	194	194	288	475	910	1,89
			7	27	74	189	189	268	441	840	1,74
			10	25	72	180	180	254	421	810	1,670
最大輸出扭矩 Max. Output Torque 急停扭矩 Emergency Stop Torque	T_{2NOT}	Nm	3 ~ 10	3 倍額定輸出力矩 3 Times of Rated Output Torque							
額定輸入轉速 Rated Input Speed	n_{1N}	rpm	3 ~ 10	3,000	3,000	3,000	3,000	3,000	3,000	3,000	3,000
最大輸入轉速 Max. Input Speed	n_{1B}	rpm	3 ~ 10	5,000	5,000	5,000	5,000	5,000	5,000	5,000	5,000
背隙 Backlash		arcmin	3 ~ 10	≤ 8	≤ 8	≤ 8	≤ 8	≤ 8	≤ 8	≤ 8	≤ 8
扭轉剛性 Torsional Rigidity		Nm/arcmin	3 ~ 10	3	5	12	12	14	23	60	140
容許徑向力 Max. Radial Force	F_{2rB}	N	3 ~ 10	350	800	1,200	1,200	3,200	5,220	8,800	14,800
容許軸向力 Max. Axial Force	F_{2aB}	N	3 ~ 10	180	400	600	600	1,600	2,600	4,400	7,400
使用壽命 Service Life	L_H	hr	3 ~ 10	S5 周期運轉 : >30,000 (S1 連續運轉 : >15,000 hrs) S5 Cycle Operation: >30,000 (S1 Continuous Operation: >15,000 hrs)							
效率 Efficiency	η	%	3 ~ 10	≥ 97%							
使用溫度 Operating Temperature		°C	3 ~ 10	- 25° C ~ + 90° C							
潤滑 Lubrication			3 ~ 10	全合成潤滑油脂 Synthetic Grease							
防護等級 Protection Class			3 ~ 10	IP65							
安裝方向 Mounting Position			3 ~ 10	任意方向 Any							
噪音值 Noise Level		dB	3 ~ 10	≤ 58	≤ 58	≤ 60	≤ 60	≤ 65	≤ 67	≤ 69	≤ 70
重量 Weight ±2%		Kg	3 ~ 10	0.64	1	1.6	1.96	3.76	7.43	16.7	33

■ 轉動慣量 Mass Moments of Inertia (kg.cm²)

Ratio	50	70	80	90	100	120	142	180
3	0.03	0.16	0.48	0.48	0.60	3.21	9.2	29.0
4	0.03	0.14	0.38	0.38	0.45	2.64	7.5	23.7
5	0.03	0.13	0.38	0.38	0.45	2.64	7.4	23.
7	0.03	0.13	0.38	0.38	0.45	2.62	7.1	22.5
10	0.03	0.13	0.35	0.35	0.41	2.51	7.0	22.5