

MODEL : TOW

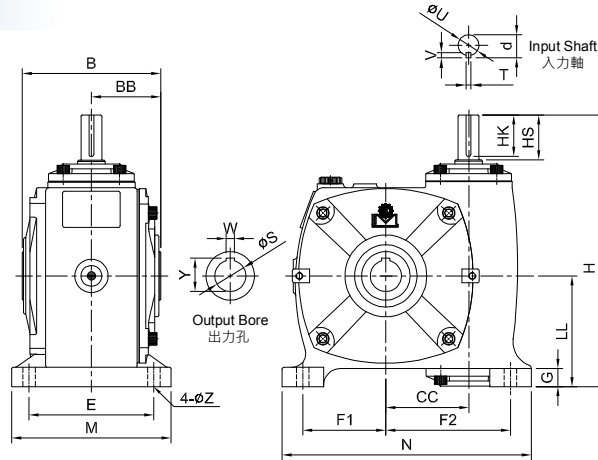

unit: mm

型號 Model	Ratio \ HP		H	LL	CC	BB	B	腳座 Foot Stock						入力軸 Input Shaft				出力孔 Output Bore			重量 Weight (kg)	
	1/10 ~ 1/30	1/40 ~ 1/60						F1	F2	E	M	N	G	Z	HS	U	d	TxVxHK	W	Y		S
60	1/2	1/4	210	90	60	57	108	67	98	105	130	200	17	11	40	15	17	5x5x35	8	28.3	25	
70	1	1/2	236	95	70	64	128	75	115	120	150	230	20	15	40	18	20	5x5x35	8	33.3	30	13.6
80	2	1	269	105	80	69	138	90	125	125	160	260	20	15	50	22	25	7x7x45	10	38.3	35	20
100	3	2	326	135	100	89	178	100	150	155	195	310	25	15	50	25	28	7x7x45	10	43.3	40	41.2
120	5	3	392	160	120	99	198	120	180	180	230	360	30	18	65	30	33	7x7x60	12	48.3	45	57.8
135	7 1/2	5	426	170	135	109	218	130	200	200	250	390	30	18	75	35	38	10x8x70	15	59.3	55	77.8

MODEL : TOM

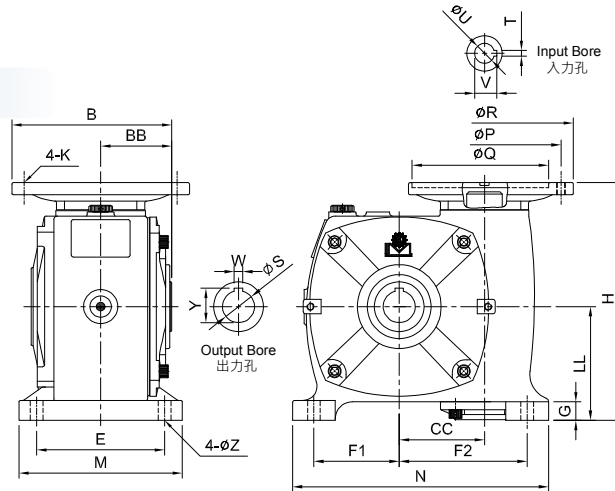

unit: mm

型號 Model	Ratio \ HP		H	LL	CC	BB	B	馬達盤 IEC Motor Flange				腳座 Foot Stock						入力孔 Input Bore			出力孔 Output Bore			重量 Weight (kg)	
	1/10 ~ 1/30	1/40 ~ 1/60						P	Q	R	K	F1	F2	E	M	N	G	Z	V	T	U	W	Y		S
60	1/2	1/4	177	90	60	57	108	130	110	160	M8	67	98	105	130	200	17	11	12.7 16.3	4 5	11 14	8	28.3	25	10.8
70	1	1/2	201 207	95	70	64	128	130 165	110 130	160 200	M8 M10	75	115	120	150	230	20	15	16.3 21.7	5 6	14 19	8	33.3	30	15.2
80	2	1	229	105	80	69	138	165	130	200	M10	90	125	125	160	260	20	15	21.7 27.2	6 8	19 24	10	38.3	35	22.4
100	3	2	282 286	135	100	89	178	165 215	130 180	200 248	M10 M12	100	150	155	195	310	25	15	27.1 31.3	8 8	24 28	10	43.3	40	43.2
120	5	3	326	160	120	100	198	215	180	248	M12	120	180	180	230	360	30	18	31.3	8	28	12	48.3	45	60
135	7 1/2	5	360 361	170	135	109	218	215 265	180 230	248 300	M12	130	200	200	250	390	30	18	31.3 41.3	8 10	28 38	15	59.3	55	78.4