

# GEAR REDUCER SERIES

## 齒輪減速機系列

### MODEL : HB

馬達插入式臥式減速機 Horizontal Type Reducer Motor Plug-In

RATIO : 1/3~1/30 (雙段 2-Stage)

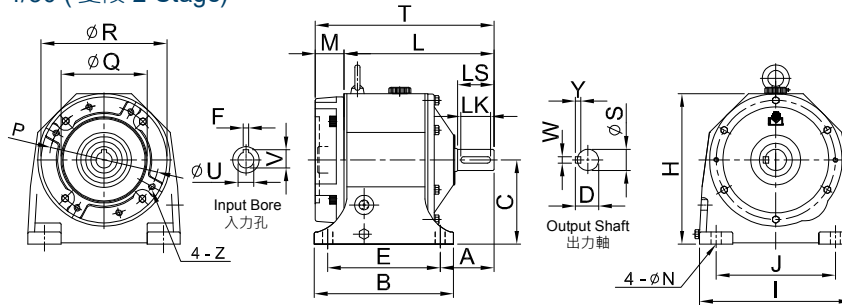

unit: mm

型號 Model	馬力 HP (4P)	減速比 Ratio	T	H	L	C	A	腳座 Foot Stock					馬達盤 IEC Motor Flange					入力孔 Input Bore			出力軸 Output Shaft			重量 Weight (kg)	油量 Oil (ℓ)		
								E	J	B	I	N	M	P	Q	R	Z	U	F	V	D	LS	S			WxYxLK	
201	1/4	3~30	194	170	165	90	54	125	140	155	180	10	29	130	110	158	M8	11	4	12.7	21	38	1	x5x30	9	0.5	
202	1/2	3~10	201	170	172	90	60	125	140	155	180	10	29	130	110	158	M8	14	5	16.3	27	45	24	7x7x35	9	0.5	
203	1/4 1/2	31~50	209	190	180	110	62	135	145	170	190	13	29	130	110	158	M8	11	4	12.7	27	45	24	7x7x35	11.5	0.7	
		11~30																									
205	1/2 1	31~50	248	227	222	127	77	170	180	210	230	15	26	130	110	200	M8	14	5	16.3	31	50	28	7x7x40	19.5	1	
		3~30	255											34	165	130	M10	19	6	21.8							
206	2	3~10	271	227	226	127	81	170	180	210	230	15	45	165	130	200	M10	24	8	27.3	35	55		x8x45	21	1	
207	1 2	31~40	299	253	254	145	80	205	195	240	260	15	34	165	130	200	M10	19	6	21.8	35	55	32	10x8x45	29	1.4	
		11~30												45				24	8	27.3							
208	3	3~10	319	265	262	145	87	205	195	240	260	15	57	215	180	250	M12	28	8	31.3	41	60	38	x8x50	30.5	1.4	
209	2 3	31~40	328	299	279									49	165	130	M10	24	27.3	41	60	38	10x8x50	42	2		
		11~30	336			164	88	215	215	265	295	19	57	215	180	250	M12	28	31.3								
209S	2 3	31~40	317	286	268									49	165	130	M10	24	27.3	41	60	38	10x8x50	40	2		
		15~30	325								280	19	57	215	180	250	M12	28	31.3								
210	5	3~10	340	299	283	164	92	215	215	265	295	19	57	215	180	250	M12	28	8	31.3	45	65		x8x55	39	2	
210S			345	273	273							280															37
211	3 5	31~40 11~30	382	332	325	192	109	250	270	295	345	19	57	215	180	250	M12	28	8	31.3	51	75		x8x65	59	3	
211S	5	11~30	355	289	298	164	105	215	215	265	295														50	2.5	
212	7 1/2 10	3~10 3~10	390	332	325	192	109	250	270	295	345	19	65	265	230	300	M12	38	10	41.3	51	75	48	12x8x65	67	3	
213	7 1/2 15	11~30 3~10	450	385	385									65	265	230	300	M12	38	10	41.3	60	80	56	15x10x70	105	6.5
			475			210	125	310	310	370	400	22	88	300	250	350	M16	42	12	45.3							
213S	7 1/2 15	11~30 3~10	447	377	382									65	265	230	300	M12	38	10	41.3	60	80	56	15x10x70	98	6.5
			482	394	394						390				88	300	250	350	M16	42	12					45.3	
214	10	11~30	455	385	390	210	130	310	310	370	400	22	65	265	230	300	M12	38	10	41.3	66	85	62	15x10x75	105	6.5	
214S			377							390																	98
215	15 20	11~30 3~10	559	445	471	245	157	360	360	430	450	25	88	300	250	350	M16	42	12	45.3	76.5	100	72	20x12x90	167	10	
216	20 25	11~30 5~10	559	445	471	245	157	360	360	430	450	25	88	300	250	350	M16	42	12	45.3	80.5	100	76	20x12x90	170	10	
217	25 30	11~30 4~30	595	505	508	280	172	380	420	460	530	25	88	350	300	400	M16	48	14	51.8	84.5	110	80	20x12x100	235	15	
			40	4~10																							
218	40 50 60	11~30 5~10	695	608		310	196	480	480	570	600	28	88	350	300	400	M16	55	16	59.3	106.5	130	100	24x16x120	364	24	
			726	626											100	400	350	450									
219	50 60	11~30	776	670	676	380	214	540	500	635	670	28	100	400	350	450	M16	60	18	64.3	124	150	115	32x20x140	541.5	32	

1. 表中 S 表示新尺寸。"S" means new dimension.

2. HB213 (含) 以上有雙油鏡雙排油孔。The model above HB213 have dual oil gauges & drain plugs.

3. 重量不含馬達及潤滑油。The weight does not include motor and lubricant.



**MODEL : HB**

馬達插入式臥式減速機 Horizontal Type Reducer Motor Plug-In  
 RATIO : 1/31~1/200 (三段 3-Stage)

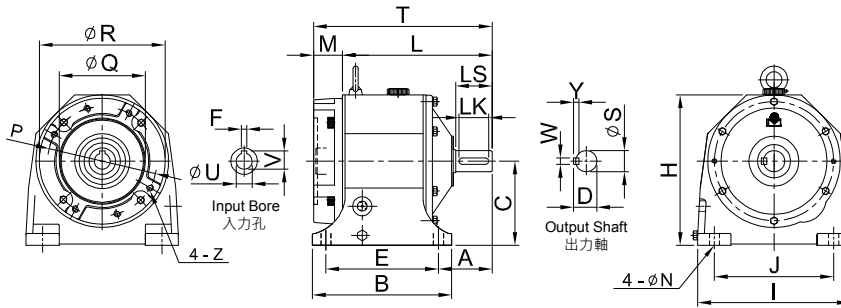

unit: mm

型號 Model	馬力 HP (4P)	減速比 Ratio	T	H	L	C	A	腳座 Foot Stock					馬達盤 IEC Motor Flange					入力孔 Input Bore			出力軸 Output Shaft			重量 Weight (kg)	油量 Oil (ℓ)		
								E	J	B	I	N	M	P	Q	R	Z	U	F	V	D	LS	S			WxYxLK	
304	1/4	51~120	220	190	194	110	68	135	145	170	190	13	29	130	110	158	M8	11	4	12.7	31	50	2	x7x40	12.5	0.7	
306	1/4	121~200	265	227	236	127	81	170	180	210	230	15	29	130	110	200	M8	11	4	12.7	35	55	32	10x8x45	21.5	1	
	1/2	51~120	285		259								26	130	110		M8	14	5	16.3							
308	1	40~120	293	253	259	145	85	205	195	240	260	15	34	165	130	200	M10	19	6	21.8	41	60	38	10x8x50	29	1.4	
	2	31~40	313		268								45				M10	24	8	27.3							
310	1	121~200	344										49	165	130		M10	19	6	21.8					45	2	
	2	51~120	289	295						295			19	57	215	180	250	M12	28	8							31.3
	3	31~50	352			164	92	215	215	265				57	215	180	250	M12	28	8							31.3
310S	1	121~200	334	286	286								49	165	130		M10	19	6	21.8					43		
	2	60~120	286							280			49	165	130		M10	24	8	27.3							
312	2	121~200	386										45	165	130		M10	24		27.3	51	75	48	12x8x65	65	3	
	3	41~120	394	332	337	192	109	250	270	295	345	19	57	215	180	250	M12	28	8	31.3							
	5	31~50	394											57	215	180	250	M12	28	8							31.3
312S	1	121~200	361	289	312	164	105	215	215	265	295		49	165	130		M10	19	6	21.8					57	2.5	
2	60~120	286											49	165	130		M10	24	8	27.3							
314	3	121~200	470		413								57	215	180	250			28	8	31	66	85	62	15x10x75	107	6.5
	5	60~120	385		402								65	265	230	300			38	10	41.3						
	7 1/2	31~50	467		402	210	130	310	310	370		22	65	265	230	300		M12	38	10	41.3						
314S	3	121~200	467		410								57	215	180	250			28	8	31.3					105	
	5	60~120	377		399								65	265	230	300			38	10	41.3						
	7 1/2	31~50	464		399								65	265	230	300			38	10	41.3						
315	5	121~200	545		488								57	215	180	250			28	8	31	76.5	100	72	20x12x90	176	10
	7 1/2	60~120	445		492	245	157	360	360	430	450	25	65	265	230	300		M12	38	10	41.3						
316	10	60~120	557	445	492	245	157	360	360	430	450	25	65	265	230	300	M12	38	10	41.3	80.5	100	76	20x12x90	184	10	
	15	31~50	580										88	300	250	350	M16	42	12	45.3							
317	7 1/2	121~200	604		539								65	265	230	300	M12	38	10	41.3	84.5	110	80	20x12x100	239	15	
	15	40~120	505		523	280	172	380	420	460	530	25	88	300	250	350	M16	42	12	45.3							
	20	40~50	611										88	300	250	350	M16	42	12	45.3							
318	10	150~200	693										65	265	230	300	M12	38	10	41.3	106.5	130	100	24x16x120	377	24	
	15	121~200	716		628								88						42	12							45.3
	20	51~120	565		650	310	196	480	480	570	600	28	88						48	14					51.8		
	25	60	737										88	300	250	350			48	14					51.8		
319	30	31~50	787										300	250	350				42	12	45.3	124	150	115	32x20x140	595	32
	20	121~200	670	699	380	214	540	500	635	670	28	88							48	14	51.8						
	25·30	70~90	808										88	350	300	400			55	16	59.3						

1. 表中 S 表示新尺寸。"S" means new dimension.  
 2. HB314(含) 以上有雙油鏡雙排油孔。The model above HB314 have dual oil gauges & drain plugs.  
 3. 重量不含馬達及潤滑油。The weight does not include motor and lubricant.