

WORM REDUCER E SERIES

蝸輪減速機 E 系列

◆ 安裝方式，依 VOF 系列安裝方向為主 (第 G38 頁)。

Please refer to Page. G38 to confirm the installation.

MODEL : EOVS

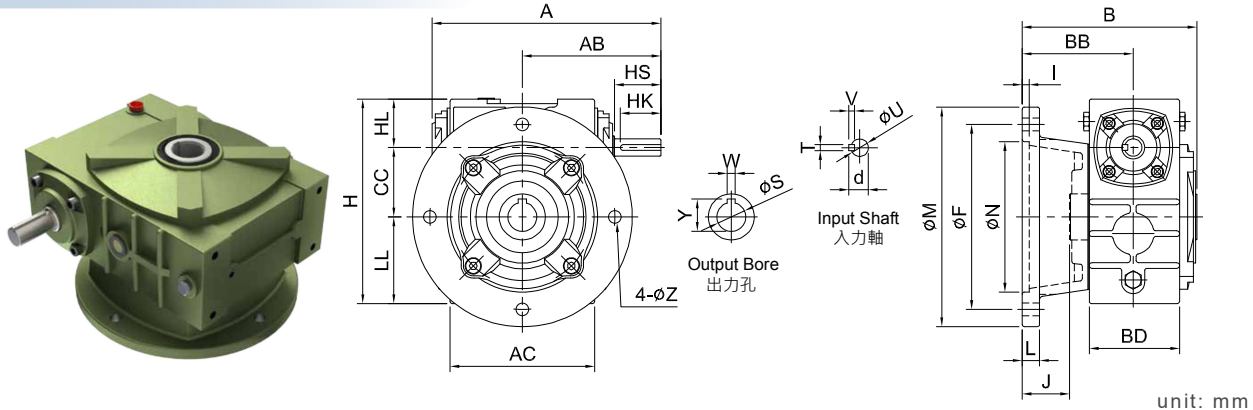

unit: mm

型號 Model	Ratio \ HP		A	AB	AC	B	BB	BD	CC	HL	LL	H	M	F	L	I	J	N	Z	入力軸 Input Shaft				出力孔 Output Bore			重量 Weight (kg)
	1/10 ~ 1/30	1/40 ~ 1/60																		HS	U	d	TxVxHK	W	Y	S	
50	1/4	-	178	105	115	145	96	70	50	35	65	150	180	150	15	6	47	120	11	30	12	13.5	4x4x25	6	22.8	20	9.2
60	1/2	1/4	198	120	124	151	96	77	60	42	75	177	190	160	15	6	42	130	11	40	15	17	5x5x35	8	28.3	25	12.2
70	1	1/2	235	140	154	179	115	85	70	50	85	205	250	215	16	6	51	180	15	40	18	20	5x5x35	8	33.3	30	18.4
80	2	1	268	161	174	184	115	96	80	60	92	232	250	215	16	6	46	180	15	50	22	25	7x7x45	10	38.3	35	24.4
100	3	2	323	190	225	234	145	116	100	75	115	290	300	265	16	5	56	230	15	50	25	28	7x7x45	10	43.3	40	41.6
120	5	3	391	231	264	244	145	132	120	95	155	370	350	300	20	7	46	260	17	65	30	33	7x7x60	12	48.3	45	63
135	7 1/2	5	438	258	306	284	175	150	135	105	185	425	400	350	24	7	66	320	18	75	35	38	10x8x70	15	59.3	55	83

MODEL : EOVM

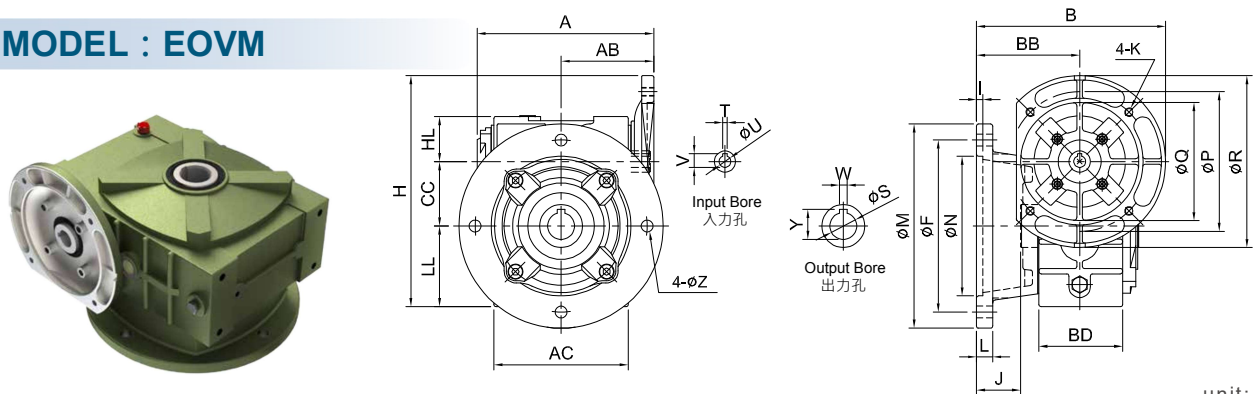

unit: mm

型號 Model	Ratio \ HP		A	AB	AC	B	BB	BD	CC	HL	LL	H	M	F	L	I	J	N	Z	馬達盤 Motor Flange				入力孔 Input Bore			出力孔 Output Bore			重量 Weight (kg)
	1/10 ~ 1/30	1/40 ~ 1/60																		P	Q	R	K	V	T	U	W	Y	S	
50	1/4	-	154	81	115	176	96	70	50	35	65	195	180	150	15	6	47	120	11	130	110	160	M8	12.7	4	11	6	22.8	20	9.6
60	1/2	1/4	165	87	124	176	96	77	60	42	75	215	190	160	15	6	42	130	11	130	110	160	M8	12.7 16.3	4 5	11 14	8	28.3	25	12.4
70	1	1/2	206	105 111	154	195 215	115	85	70	50	85	235 255	250	215	16	6	51	180	15	130 165	110 130	160 200	M8 M10	16.3 21.8	5 6	14 19	8	33.3	30	20
80	2	1	229	121	174	215	115	96	80	60	92	272	250	215	16	6	46	180	15	165	130	200	M10	21.7 27.2	6 8	19 24	10	38.3	35	26
100	3	2	280	146	225	245 270	145	116	100	75	115	315 340	300	265	16	5	56	230	15	165 215	130 180	200 250	M10 M12	27.1 31.3	8	24 28	10	43.3	40	44.6
120	5	3	333	173	264	270	145	132	120	95	155	400	350	300	20	7	46	260	17	215	180	250	M12	31.3	8	28	12	48.3	45	66.6
135	7 1/2	5	374	193	306	300 325	175	150	135	105	185	445 470	400	350	24	7	66	320	18	215 265	180 230	250 300	M12	31.3 41.3	8 10	28 38	15	59.3	55	89