



齒輪減速機系列 GEAR REDUCER SERIES

■ 馬達插入式立式減速機

VERTICAL TYPE REDUCER MOTOR PLUG-IN

■ MODEL : VB

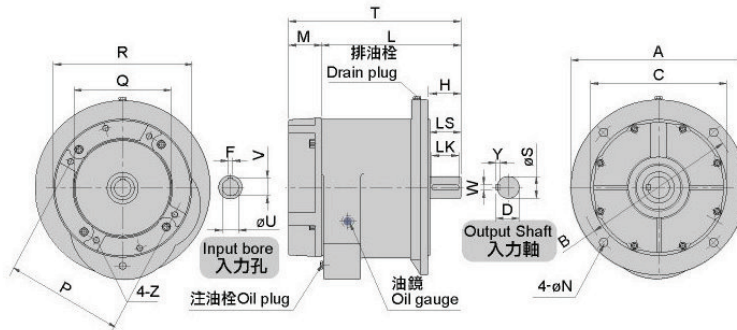

使用方向
Direction of Installation

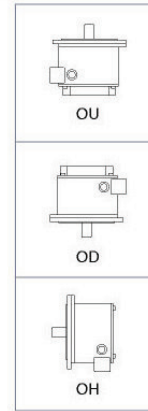

■ 二段式 2-STAGE

■ 減速比 RATIO 1/3~1/40

尺寸表 Dimension

單位 : m/m

型號 MODEL	馬力 HP (4P)	減速比 RATIO	T	L	H	法蘭面 FLANGE				馬達盤 IEC MOTOR FLANGE				入力孔 INPUT BORE			出力軸 OUTPUT SHAFT				重量 Weight (KG)	
						A	B	C	N	M	P	Q	R	Z	U	F	V	D	LS	S		WxYxLK
VB-201	1/4	3~30	172	145	43	180	155	130	10	27	130	110	160	M8	11	4	12.7	21	38	19	5x5x30	11
VB-202	1/2	3~10	180	153	50	180	155	130	10	27	130	110	160	M8	14	5	16.3	27	45	24	7x7x35	11
VB-203	1/4 1/2	31~50	228	201	50	200	175	150	12	27	130	110	160	M8	11	4	12.7	27	45	24	7x7x35	15
		11~30													14	5	16.3					
VB-205	1/2 1	31~50	237	209	55	240	215	180	14	28	130	110	200	M8	14	5	16.3	31	50	28	7x7x40	25
		3~30													19	6	21.8					
VB-206	2	3~10	257	214	60	240	215	180	14	43	165	130	200	M10	24	8	27.3	35	55	32	10x8x45	25
VB-207	1 2	31~40	266	233	60	280	245	210	14	33	165	130	200	M10	19	6	21.8	35	55	32	10x8x45	31
		11~30													24	8	27.3					
VB-208	3	3~10	291	238	65	280	245	210	14	53	215	180	250	M12	28	8	31.3	41	60	38	10x8x50	35
VB-209	2 3	31~40	305	261	65	330	300	250	18	44	165	130	250	M10	24	8	27.3	41	60	38	10x8x50	48
		11~30													28	8	31.3					
VB-210	5	3~10	309	266	70	330	300	250	18	43	215	180	250	M12	28	8	31.3	45	65	42	12x8x55	48
VB-211	3 5	31~40	348	305	80	380	335	290	18	43	215	180	250	M12	28	8	31.3	51	75	48	12x8x65	68
		11~30													28	8	31.3					
VB-212	7 1/2 10	3~10	370	305	80	380	335	290	18	65	265	230	300	M12	38	10	41.3	51	75	48	12x8x65	73
		3~10													38	10	41.3					
VB-213	7 1/2 15	11~30	423	358	85	450	400	350	22	65	265	230	300	M12	38	10	41.3	60	80	56	15x10x70	107
		4~10													42	12	45.3					
VB-214	10	11~30	428	363	90	450	400	350	22	65	265	230	300	M12	38	10	41.3	66	85	62	15x10x75	107
VB-215	15 20	11~30	522	437	105	500	450	400	24	85	300	250	350	M16	42	12	45.3	76.5	100	72	20x12x90	160
		4~10													42	12	45.3					
VB-216	20 25	11~30	520	437	105	500	450	400	24	85	300	250	350	M16	42	12	45.3	80.5	100	76	20x12x90	162
		5~10													48	14	51.8					
VB-217	25 30 40	11~30	566	479	115	590	540	480	24	87	350	300	400	M16	48	14	51.8	84.5	110	80	20x12x100	254
		4~10													55	16	59.3					
VB-218	40 50	11~30	664	577	135	660	610	560	24	87	350	300	400	M16	55	16	59.3	106.5	130	100	24x16x120	424
		5~10													60	18	64.3					
VB-219	50 60	10~30	-	654	155	700	650	600	24	-	400	350	450	M16	60	18	64.3	124	150	115	32x20x140	675

* VB-219 立式臥式兩用請洽外觀圖或內洽 * 減速比5,10,15,20,25,30,35,40,50,60,70,80,90,100,120,150,200屬於標準品，其餘皆屬於特殊品。



■ 馬達插入式立式減速機

VERTICAL TYPE REDUCER MOTOR PLUG-IN

■ MODEL : VB

使用方向
Direction of Installation

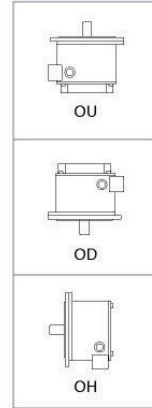
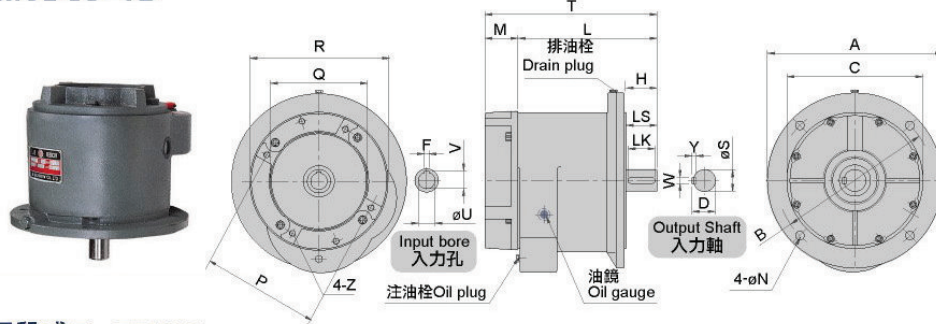

■ 三段式 3-STAGE

■ 減速比 RATIO 1/31~1/200

尺寸表 Dimension

單位 : m/m

型號 MODEL	馬力 HP (4P)	減速比 RATIO	T	L	H	法蘭面 FLANGE				馬達盤 IEC MOTOR FLANGE					入力孔 INPUT BORE			出力軸 OUTPUT SHAFT				重量 Weight (KG)
						A	B	C	N	M	P	Q	R	Z	U	F	V	D	LS	S	WxYxLK	
VB-304	1/4	51~120	214	187	55	200	175	150	12	27	130	110	160	M8	11	4	12.7	31	50	28	7x7x40	17
VB-306	1/4	121~200	250	222	60	240	215	180	14	28	130	110	160	M8	11	4	12.7	35	55	32	10x8x45	27
	1/2	51~120	262	234											14	5	16.3					
VB-308	1/2	121~200	274	246 238	65	280	245	210	14	28	130	110	200	M8	14	5	16.3	41	60	38	10x8x50	32
	1	40~120	271							8	27.3											
	2	31~40	282							8	27.3											
VB-310	1	121~200	313	269	70	330	300	250	18	44	165	130	200	M10	19	6	21.8	45	65	42	12x8x55	53
	2	51~120								8	27.3											
	3	31~40								322	8	31.3										
VB-312	2	121~200	359	315	80	380	335	290	18	44	165	130	200	M10	24	8	27.3	51	75	48	12x8x65	75
	3	41~120								8	31.3											
	5	31~50								368	8	31.3										
VB-314	3	121~200	421	378 366	90	450	400	350	22	43	215	180	250	M12	28	8	31.3	66	85	62	15x10x75	115 120
	5	51~120								8	31.3											
	7 1/2	31~50								431	10	41.3										
VB-315	5	121~200	495	452	105	500	450	400	24	43	215	180	250		28	8	31.3	76.5	100	72	20x12x90	171 184
	7 1/2	35~120								38	10	41.3										
	10	35~60								517	38	10	41.3									
VB-316	10	35~120	517	452	105	500	450	400	24	65	265	230	300	M12	38	10	41.3	80.5	100	76	20x12x90	172 185
	15	31~60								42	12	45.3										
	7 1/2	125~200								544	38	10	41.3									
VB-317	15	40~120	564	479	115	590	540	480	24	65	265	230	300	M12	38	10	41.3	84.5	110	80	20x12x100	244 252 268
	20	40~50								42	12	45.3										
	25	40~50								566	48	14	51.8									
	10	121~200								662	38	10	41.3									
VB-318	15	121~200	682	597	135	660	610	560	24	85	300	250	350	M16	42	12	45.3	106.5	130	100	24x16x120	400 408 424 424
	20	51~120								42	12	45.3										
	25	60								684	48	14	51.8									
	30	31~50								684	48	14	51.8									
	20	121~200								759	42	12	45.3									
VB-319	25	70~90	761	674	155	700	650	600	24	87	350	300	400	M16	48	14	51.8	124	150	115	32x20x140	637 653
	30	70~90								87	350	300	400	M16	48	14	51.8					
	40	40~60								761	55	16	59.3									
	20	121~200								662	38	10	41.3									

※ VB-319 立臥兩用請看外觀圖或內洽 ※ 減速比 5, 10, 15, 20, 25, 30, 35, 40, 50, 60, 70, 80, 90, 100, 120, 150, 200 屬於標準品，其餘皆屬於特殊品。